

2007
LAWN & GARDEN TRACTORS
Saturday September 1st

2 &4-WHEEL DRIVE ATV'S
Sunday, September 2nd

PULLING CONTESTS

RAMONA CHESSMAN, DIRECTOR

DAVID CHESSMAN,
MANAGER

236 Pleasant Valley Road
Lancaster, NH 03584

Tel: 603/788-4679

**LAWN AND GARDEN
TRACTOR
PULLING CONTESTS
Saturday, September 1st**

All Lawn & Garden tractors must enter through Stockwell Road Green Gate off Route 3. Purchase entry ticket at gate.
Weigh-in: All tractors must cross the scales prior to each class.

All entrants are subject to be re-weighed at the discretion of the judges.

RULES: Lancaster Fair Tractor Pulling will be judged by one or more officials. The judges will have sole discretion as to the interpretation of the rules and actions that may or may not fall under these written rules. Any disruption that results in a disqualification will also result in forfeiture of all prize money from other classes in this event.

OPERATORS: No minor under the age of 18 will be allowed to pull without the written permission of his or her parent or legal guardian. All operators must be in complete control of their tractors at all times. Unsafe acts, in the ring or out, will result in immediate disqualification. Excessive speed will not be tolerated!! ATV operators must have a helmet, long sleeve shirt and long pants.

The possession of alcohol, or the intoxication of any entrant, in or around the pulling area, will result in immediate disqualification or forfeiture of prizes and removal from the fairgrounds.

Time and Place:

Registration starts at 9 am, 1st class to pull at 10:30 am in Tractor Pulling area located in the right rear corner of the Fair Grounds.

(Must enter through Stockwell Road Green gate only!)

TENTATIVE CLASS SCHEDULE:

1. 850# Stock(14 years of Age & Under)
2. 750# 8" Tires Super Stock
3. 1050# Stock
4. 1000# Super Stock
5. 1000# Open

(Classes subject to change without notice)

A minimum of two entrants per class is required for each class.

1st - \$40.00; 2nd - \$20.00;
3rd - \$10.00; 4th - \$5.00.

Lawn & Garden Tractor Pull

General Rules

1. There will be only one driver per tractor, per class.
2. All weights must be secure on tractor as not to fall off during the pull.
3. Loss of weight when still hooked to the sled will cause disqualification.
4. There will be no weights on the tractor seat.
5. Driver must remain sitting at all times. No bouncing in the seat.
6. There will be immediate disqualification for going out of bounds. Out of bounds is defined as touching the white line. (Pulling tractor only—doesn't mean sled)
7. Driver may be test puller in one class only.
8. No chains, cleats, tracks, dual wheels or four wheel drives.
9. No diesel or snowmobile engines.
10. Must use pump gas only in all classes.
11. All drivers must wear a helmet, if promoter of event requires them.
12. 4 Cycle, Lawn Mower type engines, must be used in all classes.
13. All engines must be stock in appearance.
14. Before any tractor can pull, both tractor and driver must be registered and weighted in before the event starts.
15. The decisions of the judges will be final.
16. Any class may be dropped if there are less than three tractors registered before the class starts.
17. No jumping classes from stock and super stock to open division.
18. Pullers who sign up below the last line (16), when the lines above are available will not be allowed to hook.
19. The top three finishing tractors will be required to re-weigh and draw bars checked.

Rules For Sled Operation

1. The first tractor in every class will be the test puller. They have the option of taking the pull, re-pull immediately or dropping three places to re-pull.
2. A puller may stop before the 15' mark on a 50' track, and 25' mark on a 100' track and re-pull again immediately, but only once.
3. If a puller has a mechanical problem, they may drop to last puller.
4. Each puller has three minutes from the time they are called to hook to the sled.

5. Two or more full pulls will result in a pull off. This will be held in the same order as the first pull.
6. We reserve the right to re-weigh any tractor in every class at the end of the class.
7. Each puller has the option of spotting the sled as it is being returned to the starting line from the previous pull. This is done by placing the traffic cone where you want the centerline of the sled.
8. In a pull off situation, puller must pull in the same order as they pulled in the first round.
9. In a pull off situation, a puller will be allowed one hook only. The 15' and 25' restart rule does not apply.
10. In the stock class, the sled operator will set a speed limit at the start of the event.
11. The sled operator has the option to choose the tractor that he wants to set the sled by. This tractor will not be the test puller. The tractor will go to its original pulling position.

Stock Division

1. All tractors must be stock in appearance with a stock transmission and rear-end. Lock rear-ends are allowed.
2. All tractors must have a seat, hood and grill.
3. Turf tires only. No cut tires allowed. Tires must be no larger than 23X10.50X12.
4. All tractor engines will be original manufactured brand.
5. Horsepower will be limited to manufactures, original specification per model per year.
6. All intake and exhaust ports must be as cast finish.
7. All tractor engines will run at 3600 RPM or under. If there is a question, in the RPM it will be checked by a photo tack.
8. There will be no straight pipes or headers. Mufflers are required.
9. Drawbar will be in the stock location, no higher than 12" to the top of the hitch with a minimum of 1 5/8" hole for the Sugar Hill Snubber hook.
10. A speed restriction will be set at the start of the event.
11. 4 cycle, air cooled lawn mower type engines must be used.
12. The first three finishers will be re-weighed, RPM checked, and drawbar height of 12" to the top of the hitch will be checked.
13. Stock tractors will be required to have two functional wheelie bars that are to meet Snubber specs.(See diagram, page 46). Tractors that do not have wheelie bars will use the Snubber safety hitch for a maximum of three events.

8" Super Stock

1. Must be stock manufactured tractor in appearance, with a stock transmission and rear-end. Lock rear-ends are allowed.
2. Frame modifications are allowed as long as original wheelbase is maintained.
3. Tractor must have one engine.
4. All engines must be 18 horsepower or under. Briggs & Stratton Engines only, 4cycle, air cooled lawn type engines only.
5. All engines must be stock appearance, no external modifications.
6. No internal modifications will be allowed except for a maximum of .060 over bore to renew cylinder bore for rebuilding.
7. No fuel injection allowed on gas engine.
8. Headers and Straight pipes are allowed.
9. Two functional wheelie bars required meeting Snubber specs (See diagram, page 46)
10. Wheelie bars must support the weight of the tractor and all weights to be used.
11. All drawbars must have 1 5/8" hole for hook.
12. All drawbars will be no higher than 12" and rigid in all directions, maintained throughout the class.
13. Turf tires only, Cutting to enhance traction is allowed. Tires cannot exceed 10.50X8X12
14. All tractors must have a hood, seat and grill.
15. No weigh bars or weights may exceed 18" from the front of the front axle.

12" Super Stock

1. Must be stock manufactured tractor in appearance, with a stock transmission and rear-end. Lock rear-ends are allowed.
2. Frame modifications are allowed as long as original wheelbase is maintained.
3. Tractor must have one engine.
4. All engines must be 18 horsepower or under. Briggs & Stratton Engines only, 4cycle, air cooled lawn type engines only.
5. All engines must be stock appearance, no external modifications.
6. No internal modifications will be allowed except for a maximum of .060 over bore to renew cylinder bore for rebuilding.
7. No fuel injection allowed on gas engine.
8. Headers and Straight pipes are allowed.
9. Two functional wheelie bars required meeting Snubber specs (See diagram, page 46)
10. Wheelie bars must support the weight of the tractor and all weights to be used.

11. All drawbars must have 1 5/8" hole for hook.
12. All drawbars will be no higher than 12" and rigid in all directions, maintained throughout the class.
13. Turf tires only, Cutting to enhance traction is allowed. Tires cannot exceed 10.50X8X12
14. All tractors must have a hood, seat and grill.
15. No weigh bars or weights may exceed 18" from the front of the front axle.

Open Division

1. Tractors may be home built with a wheelbase no more than 67"
2. All engines must be 4-cycle lawn mower type engine, stock in appearance.
3. Multi-engine combinations are allowed. All engines horsepower must not amount to more than 25 horsepower and be stock in appearance.
4. All tractors must run pump gas only.
5. No fuel injection allowed.
6. Header and straight pipes are allowed.
7. All tractors must have two functional wheelie bars with pads or wheels that meet Snubber specs (See diagram, page 46)
8. Wheelie bars must support the weight of the tractor and all weights to be used in all classes.
9. All drawbars must be no higher than 12" to top of hitch, ridged in all directions, maintained throughout the class, with a 1 5/8" hole for hook.
10. All tires will have a diameter of no more than 26" and tread width of no more than 12".
11. All tires used in the open class will cost no more than \$100.00 per tire.
12. Twin cylinder engines or multi single cylinder engines only. Engine or engine combo not to exceed 25 horsepower.
13. No weigh bars or weights may exceed 18" from the front of the front axle.

8" wheelie bar dimension below. Wheels and pads are allowed.

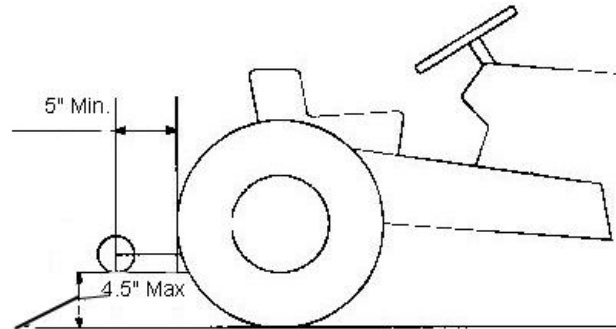

This dimension changes to 5 inches for the 12 inch rear wheel tractors

Top View

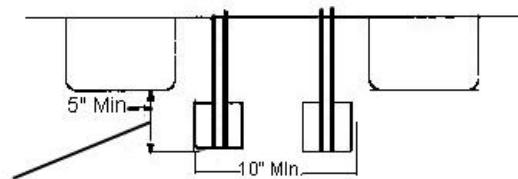

If wheels are used this dimension is to the center of wheel.

**ATV
PULLING CONTESTS
Sunday, September 2nd, 2007**

All ATV's must enter through Stockwell Road Green Gate off Route 3. Purchase entry ticket at gate.

Weigh-in: All ATV's must cross the scales prior to each class.

All entrants are subject to be re-weighed at the discretion of the judges.

RULES: Lancaster Fair ATV Pulling will be judged by one or more officials. The judges will have sole discretion as to the interpretation of the rules and actions that may or may not fall under these written rules. Any disruption that results in a disqualification will also result in forfeiture of all prize money from other classes in this event.

OPERATORS: No minor under the age of 18 will be allowed to pull without the written permission of his or her parent or legal guardian. All operators must be in complete control of their ATV's at all times. Unsafe acts, in the ring or out, will result in immediate disqualification. Excessive speed will not be tolerated!! ATV operators must have a helmet, long sleeve shirt and long pants.

The possession of alcohol, or the intoxication of any entrant, in or around the pulling area, will result in immediate disqualification or forfeiture of prizes and removal from the fairgrounds.

Time and Place:

ATV's: Registration starting at 8:30 am, 1st class to pull at 10:00 am in Tractor Pulling area located in the right rear corner of the Fair Grounds.

(Must enter through Stockwell Road Green gate only!)

CLASS SCHEDULE:

STOCK

1. ATV 2wheel Drive up to 300cc 800# max wt.
2. ATV 2wheel Drive 301cc to 450cc 900# max wt.
3. ATV 4wheel Drive up to 300cc 900# max wt.
4. ATV 4wheel Drive 301cc to 450cc 1000# max wt.
5. ATV 4wheel Drive 451cc to 599cc 1100# max wt.
6. ATV 4wheel Drive 600cc to 700cc 1200# max wt.

OPEN

7. ATV 2wheel Drive up to 450cc 975# max wt.

8. ATV 4wheel Drive up to 300cc 975# max wt.
9. ATV 4wheel Drive up to 301cc to 450cc 1100# max wt.
10. ATV 4wheel Drive 451cc to 599cc 1350# max wt.
11. ATV 4wheel Drive 600cc to 700cc 1450# max wt.

A minimum of two entrants per class is required for each class.

1st - \$40.00; 2nd - \$20.00; 3rd - \$10.00; 4th - \$5.00.

**ATV PULL
GENERAL RULES**

1. All operators must attend drivers meeting 15 minutes before pull.
2. Contest will be governed by three or more judges with all decisions final.
3. No crew coaching on track.
4. Spectators and other operators are not permitted on track.
5. VIOLATIONS OF ANY RULE WILL RESULT IN DISQUALIFICATION.
6. JUDGES MAY STOP AND DISQUALIFY ANY OPERATOR NOT OPERATING SAFELY.
7. ANY OPERATOR, OWNER, OR PIT CREW MEMBER DISRUPTING THE PULL, WHETHER IN PITS OR ON TRACK, WILL BE DISQUALIFIED FOR THE REST OF THE EVENT. ALL TROPHIES, RIBBONS, AND/OR MONEY WILL BE RETURNED TO JUDGES IMMEDIATELY.
8. ANY PROTEST AGAINST OPERATORS AND/OR EQUIPMENT MUST BE MADE BY THE END OF THE CLASS.
9. ANYONE INVOLVED IN A FIGHT, RIGHT OR WRONG, WILL BE DISQUALIFIED FOR REMAINDER OF EVENT.

OPERATORS

1. Written permission of owner or parent is required if operator is under 18 years old.
2. No switching with classes.
3. Must remain SEATED, be in full control & operate in a safe manner.
4. Owners will assume full responsibility for neg-

ligence and/or accidents.

5. NO ALCOHOLIC BEVERAGES BEFORE, DURING OR AFTER THE PULL ON THE GROUNDS.

SAFETY

1. Safe operation required at all times.
2. ATV must stop immediately on signal of judge.
3. Must be in neutral or park when hitching or unhitching.
4. NO PASSENGERS ANYWHERE OR ANY-TIME DURING THE EVENT WHILE ON GROUNDS.
5. HELMETS MUST BE WORN AND HITCHED.
6. FIVE MILE PER HOUR SPEED LIMIT ON GROUNDS.

PULLING

1. ATV's may be entered in two classes per event, once per class.
2. Random draw order, drawn at weigh in.
3. At least two entries required per class, or class cancelled.
4. Pulling will be done off a weight transfer sled.
5. Test puller may pull again immediately after the sled has been set or drop to THIRD.
6. All decisions on re-pull must be made before unhitching.
7. All pulls start with tight hitch, no jerk pulls permitted.
8. Allowed two attempts with 25 feet to make measurable pull.
9. Operators have the option of spotting sled on starting line.
10. Class starts with three full pulls, weight will be added to sled and fourth puller goes first.
11. ATV's missing their turn will pull last.
12. ATV's must stay in boundaries or be disqualified.

ATV'S: STOCK-CLASS

1. Out of shop, rubber tires, standard tread, set in forward rotation, no tires with tread bars run-

ning the full width of the tire.

2. No cut or ground tires.
3. Drawbar-stock only with straight or twisted clevis.
4. No alternate fuels, original equipment only.
5. Hitch point with minimum 2 inch opening, standard or twisted clevis.
6. Must have working brake.
7. Must have working suspension.
8. Two wheel drive—two wheel drive class only.
9. Four wheel drive—four wheel drive class only.

OPEN-CLASS

1. Must fall under CC and Weight guidelines.
2. Maximum hitch height: 14 inches.
3. Maximum hitch length: 12 inches.

WEIGHT

1. Added weight and/or brackets securely attached to frame, wheels or rack.
2. No weight beyond racks, front or back.
3. No weight on seat, footrest or drawbar.
4. If weight falls off—DISQUALIFIED.
5. MUST EXIT DIRECTLY TO SCALES.
6. All hitches will be measured with driver and weights while sitting on the scale in seat.
7. Scales will be open two hours prior to pull.